

M-410iC/500



Max. load capacity
at wrist: 500 kg



Max. reach:
3143 mm

FANUC

Robot			Max. load capacity at wrist (kg)	Reach (mm)	Controlled axes	Repeatability (mm)	Mechanical weight (kg)	Motion range (°)						Maximum speed (°/s)						J4 Moment/ Inertia	J5 Moment/ Inertia	J6 Moment/ Inertia	Average Power consumption (kW)	Protection	
Series	Version	Type						J1	J2	J3	J4	J5	J6	J1	J2	J3	J4	J5	J6					Body standard/optional	Wrist & J3 arm standard/optional
M-410	iC	500	500	3143	4	± 0.05	2410 (1910)	370	144	136	720	-	-	85	85	85	200	-	-	250	-	-	3	IP54	IP54

[no pedestal] ● standard ○ on request - not available ** Based on ISO9283

M-410iC/500

Hollow wrist



Rear side
Interference area

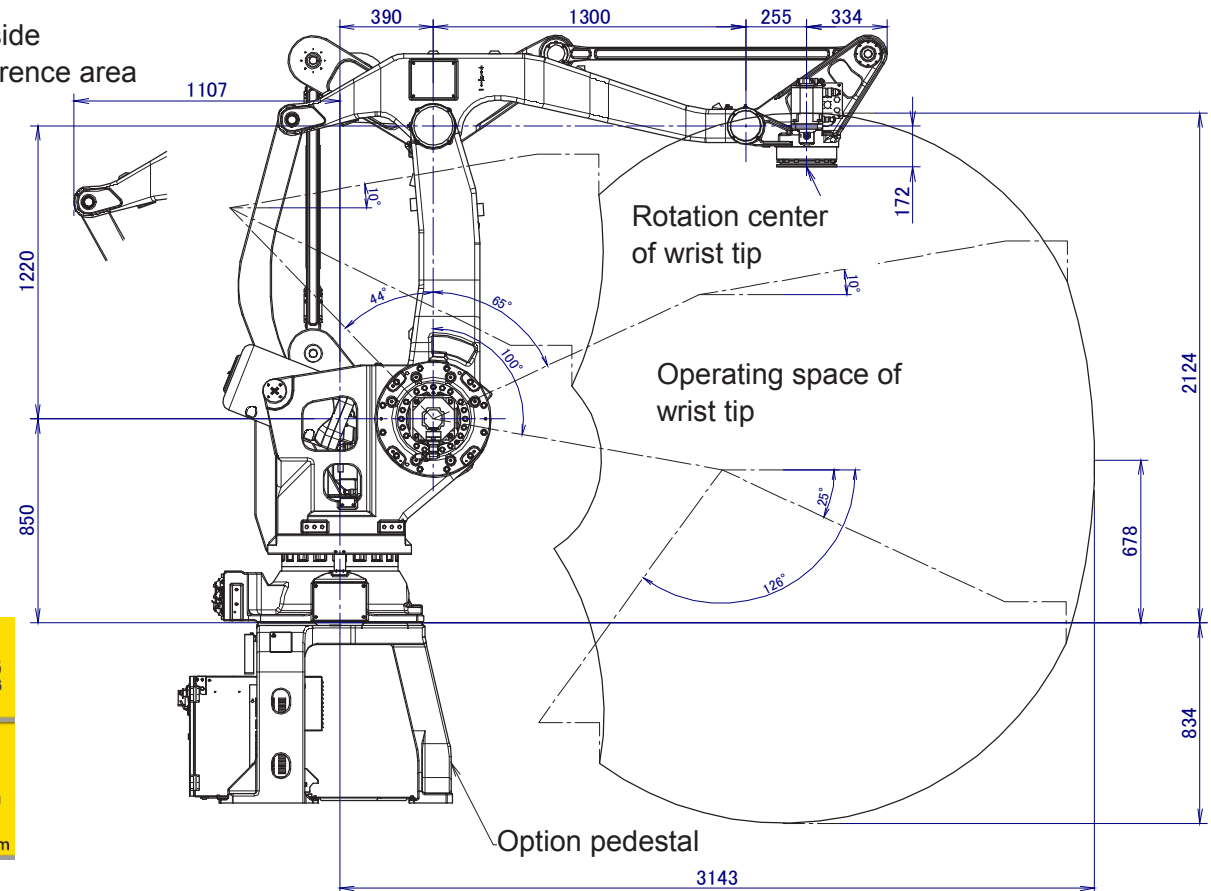

M-410iC/500

MOTION CONTROLS ROBOTICS
1500 Walter Ave, Fremont, OH 43420

CONTACT SALES
419.334.5886
sales@mcri-us.com
Click for a quote
motioncontrolsrobotics.com

FANUC
AUTHORIZED SYSTEM INTEGRATOR
CERTIFIED SERVICE PROVIDER