

# M-10iD/8L



Max. load capacity at wrist: **8 kg**



Max. reach: **2032 mm**

Controlled axes	Repeatability (mm)	Mechanical weight (kg)	Motion range (°)						Maximum speed (°/s)						J4 Moment/Inertia (Nm/kgm <sup>2</sup> )	J5 Moment/Inertia (Nm/kgm <sup>2</sup> )	J6 Moment/Inertia (Nm/kgm <sup>2</sup> )
			J1	J2	J3	J4	J5	J6	J1	J2	J3	J4	J5	J6			
6	± 0.03*	180	340 (370)	235	455	380	360	900	210	210	220	430	450	720	16.1/0.63	16.1/0.63	5.9/0.061

## Working range

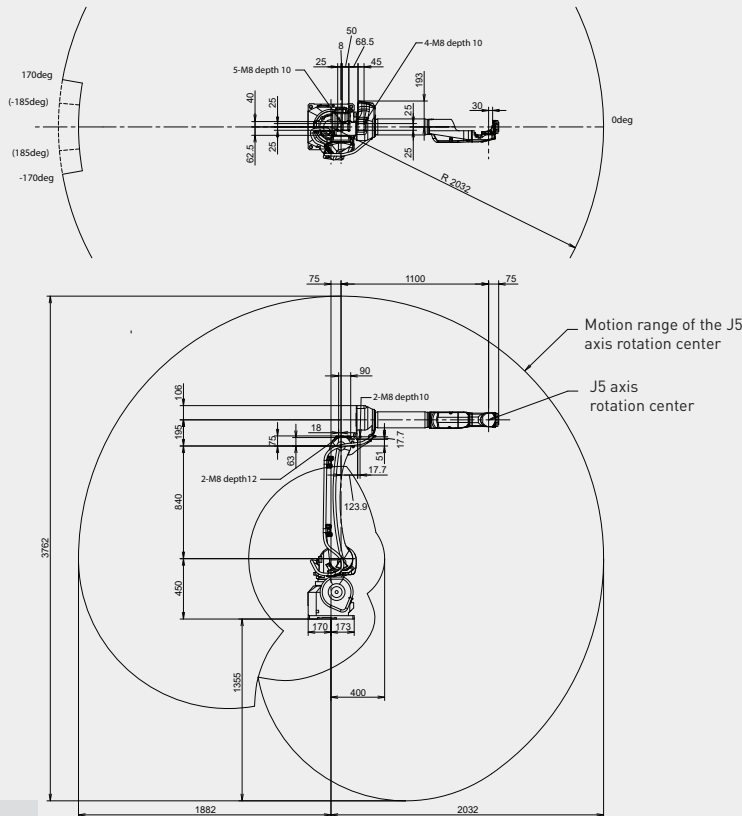

Motion range may be restricted according to the mounting angle!

## Robot

Robot footprint [mm]	<b>M-10iD/8L</b> 343 x 343
Mounting position Floor	●
Mounting position Upside down	●
Mounting position Angle	●

## Controller

Open air cabinet	<b>R-30iB Plus</b> -
Mate cabinet	○
A-cabinet	●
B-cabinet	○
iPendant Touch	●

## Electrical connections

Voltage 50/60Hz 3phase [V]	380-575
Voltage 50/60Hz 1phase [V]	-
Average power consumption [kW]	1

## Integrated services

Integrated signals on upper arm In/Out	8/8
Integrated air supply	1

## Environment

Acoustic noise level [dB]	57.4
Ambient temperature [° C]	0-45

## Protection

Body standard/optional	IP54
Wrist & J3 arm standard/optional	IP67

● standard ○ on request - not available ( ) with hardware and/or software option

\*Based on IS09283