

# SR-3iA/H



Max. load capacity at wrist: 3 kg



Max. reach: 400 mm

# FANUC

Robot			Max. load capacity at wrist (kg)	Reach (mm)	Controlled axes	Repeatability (mm)	Mechanical weight (kg)	Motion range (°)						Maximum speed (°/s)						Moments (N-m)/Inertia (kg-m <sup>2</sup> )			Push Force (N)	Protection	
Series	Version	Type						J1	J2	J3	J4	J5	J6	J1	J2	J3	J4	J5	J6	J4 Moment/Inertia	J4 Moment/Inertia	J4 Moment/Inertia		Body standard/optional	Wrist & J3 arm standard/optional
SR	iA/H	3	3	400	3	±0.01 (J1, J2) ±0.01 (J3)	17	±142	±145	200 mm*	-	-	-	720	780	1800 mm/s*	-	-	-	-/0.06	-	-	150	IP20	IP20

- not available \* z axis

SR-3iA/H 3-axis



SR-3iA/H

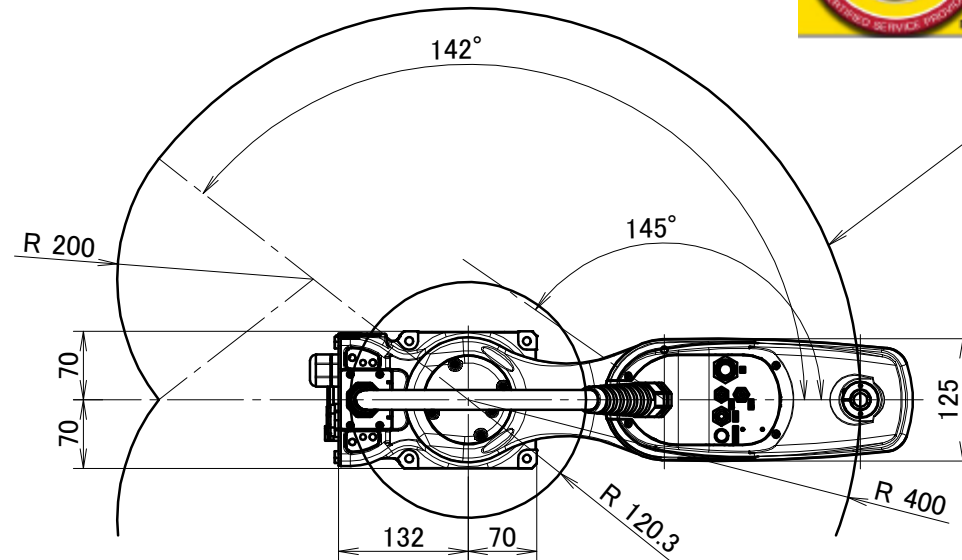

Operating space of J4-axis rotation center

**MOTION CONTROLS ROBOTICS**  
 1300 Walter Ave, Fremont, OH 43420  
 Contact Sales  
 419.334.5886  
 sales@mcri-us.com  
 Click for a quote  
 motioncontrolsrobotics.com