

SR-6iA



Max. load capacity at wrist: 6 kg



Max. reach: 650 mm

FANUC

Robot			Max. load capacity at wrist (kg)	Reach (mm)	Controlled axes	Repeatability (mm)	Mechanical weight (kg)	Motion range (°)						Maximum speed (°/s)						J4 Moment/Inertia	J5 Moment/Inertia	J6 Moment/Inertia	Average Power consumption (kW)	Protection	
Series	Version	Type						J1	J2	J3	J4	J5	J6	J1	J2	J3	J4	J5	J6					Body standard/optional	Wrist & J3 arm standard/optional
SR	iA	6	6	650	4	±0.01 (J1, J2) ±0.01 (J3) ±0.004° (J4)	30	±148	±150	210 mm*	±720	-	-	440	700	2000 mm/s	2500	-	-	--/0.12	,	,	0.2	IP20	IP20

● standard ○ on request - not available * z axis ** Based on ISO9283

SR-6iA 4-axis



SR-6iA

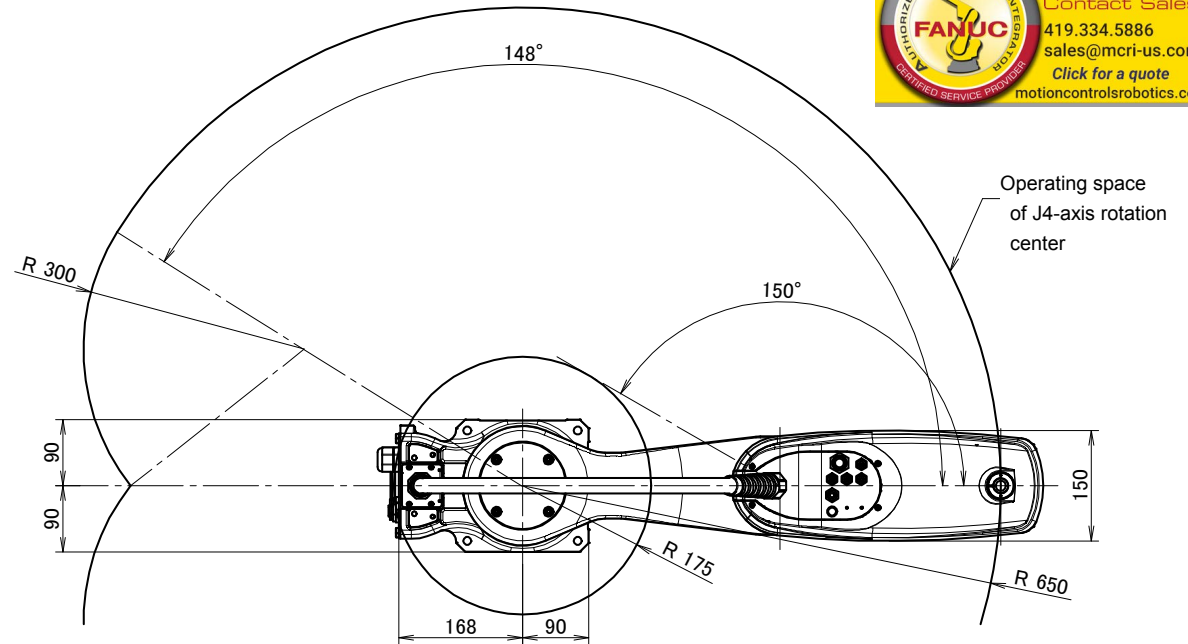

MOTION CONTROLS ROBOTICS
 1500 Walter Ave, Fremont, OH 43420
 CONTACT SALES
 419.334.5886
 sales@mcri-us.com
 Click for a quote
 motioncontrolsrobotics.com

FANUC
 AUTHORIZED SYSTEM INTEGRATOR
 CERTIFIED VISION SPECIALIST
 CERTIFIED SERVICE PROVIDER