

M-41 0iC/315 [Hollow wrist]



Max. load capacity
at wrist: **315 kg**



Max. reach:
3143 mm

Controlled axes	Repeatability [mm]	Mechanical weight [kg]	Motion range [°]						Maximum speed [°/s]						J4 Moment/Inertia [Nm/kgm ²]	J5 Moment/Inertia [Nm/kgm ²]	J6 Moment/Inertia [Nm/kgm ²]
			J1	J2	J3	J4	J5	J6	J1	J2	J3	J4	J5	J6			
4	± 0.5	1600 [1300]	360	144	136	720	-	-	90	100	110	195	-	-	155	-	-

Working range

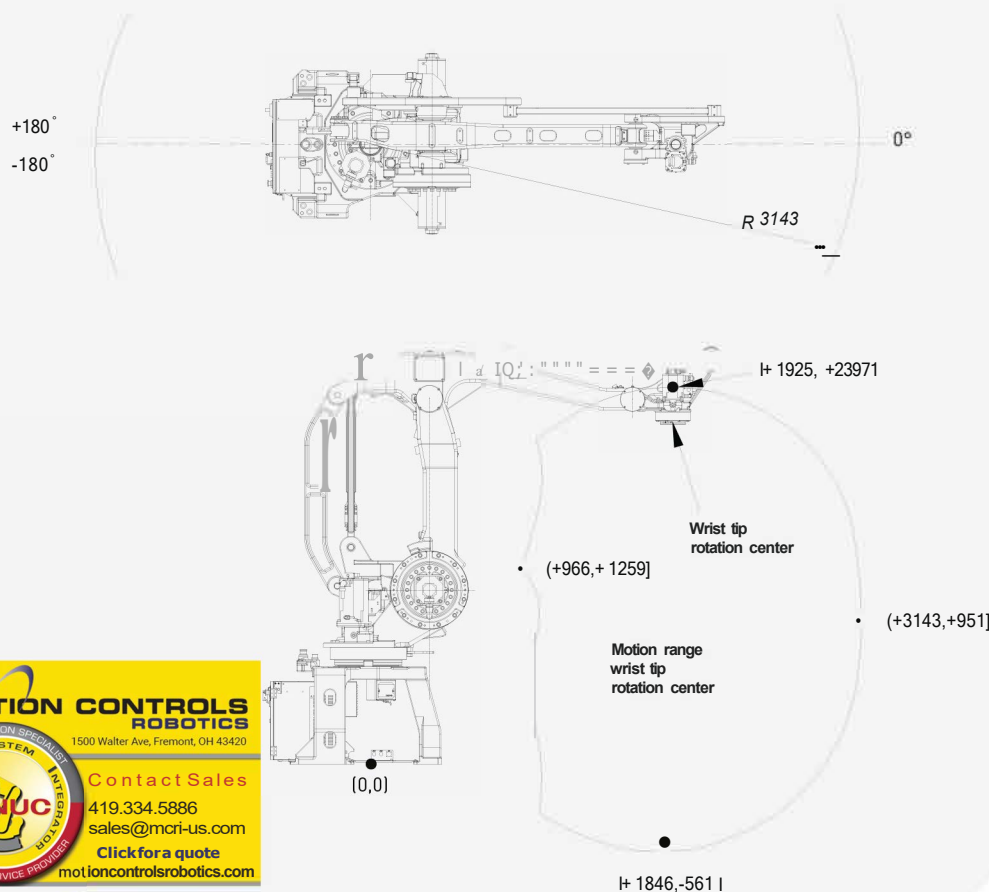

I Robot

	M-410iC/315
Robot footprint [mm]	1094 x 945 (806 x 610)
Mounting position -> floor	•
Mounting position -> side of floor	-
Mounting position angle	-

W Controller

	R-30iB Plus
Open air cabinet	-
Mate cabinet	-
A-cabinet	•
B-cabinet	o
iPendant Touch	•

Electrical connections

VC>ltage_5_0_/_6.0_Hz_3phase_[V]_	380-575
VC>ltage_50/60Hz_1phase_[V]_	-
Average_poVJer_consult)ption_[kV]_	1
Integrati?d_signals_on_upper_arm)_In/Out	8/8
Integrati?d_air_supply	1

Environment

Acoustic noise level [dB]	75.3
Ambient temperature [° C]	0-45

Protection

Body_standard/optional	IP54
Wrist & J3 arm standard/optional	IP54

• standard o on request - not available l) with hardware and/or software option

MOTION CONTROLS ROBOTICS
1500 Walter Ave, Fremont, OH 43420
Contact Sales
419.334.5886
sales@mcr-us.com
Click for a quote
motioncontrolsrobotics.com