

Features

The LR Mate 200iD is a compact six-axis mini robot with the approximate size and reach of a human arm.

- Slim arm minimizes interference to peripheral devices and allows operation in narrow spaces.
- Standard arm (717mm reach), short arm (550mm reach), long arm (911mm reach), food/clean-room, wash-proof and 5-axes high speed models are available.
- Lightest mechanical unit in its class enables easy system integration and installation flexibility with multiple mounting methods.
- The most advanced servo technology and highly rigid arm enable smooth motion without vibration in high-speed operations.
- Enhanced wrist load capacity allows for greater efficiency and the ability to handle multiple workpieces.
- Vision and force sensor cables (option), auxiliary axis cable (option – limited model types), solenoid valve, air tube and I/O cable for device control are integrated into the arm for easy cable handling.
- IP69K (robot option - limited model types) provides enhanced dust and water protection in harsh environments. Available bottom cable exit (option) also protects cable from harsh environments.
- High performance R-30iB Mate controller has two types – standard enclosed controller that enables reliable operation under a factory environment with dust and oil mist, and compact controller for clean environment.
- Various intelligent features are available as an option, such as iRVision (integrated vision) and force sensing.



Application system

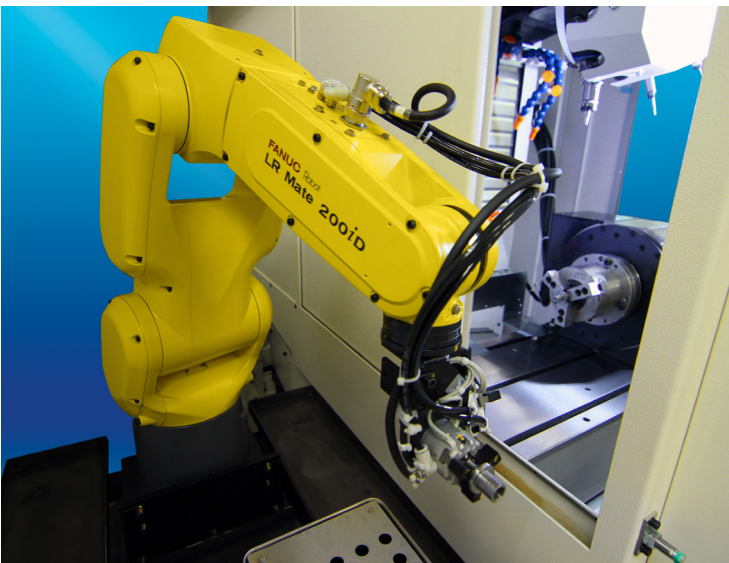

Machine Load/Unload

FANUC Robot LR Mate 200iD

Operating space

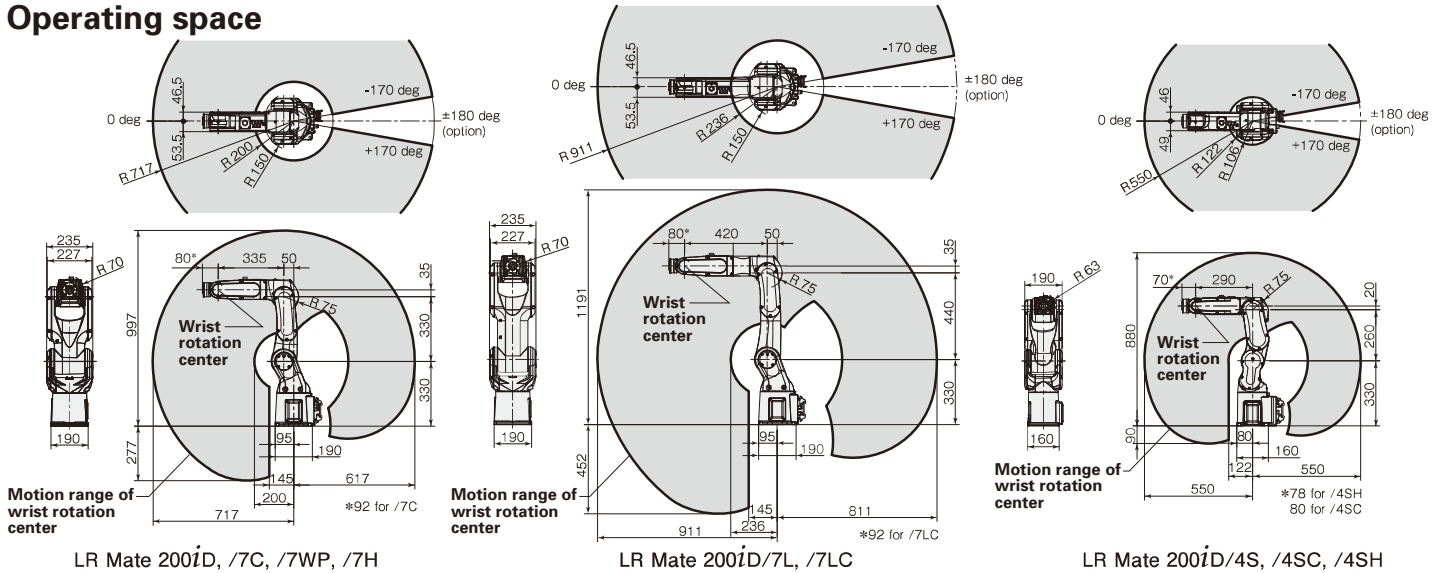

Specifications

Model	LR Mate 200iD LR Mate 200iD/7C LR Mate 200iD/7WP	LR Mate 200iD/7H	LR Mate 200iD/7L LR Mate 200iD/7LC	LR Mate 200iD/4S LR Mate 200iD/4SC	LR Mate 200iD/4SH	
Controlled axes	6 axes	5 axes	6 axes	6 axes	5 axes	
Reach	717 mm		911 mm	550 mm		
Installation (Note 2)	Floor, Upside-down, Angle mount					
Motion range (Maximum speed)	J1 axis	340°/360°(option) (450°/s) 5.93 rad/6.28 rad (option) (7.85 rad/s)	340°/360°(option) (370°/s) 5.93 rad/6.28 rad (option) (6.46 rad/s)	340°/360°(option) (460°/s) 5.93 rad/6.28 rad (option) (8.03 rad/s)		
	J2 axis	245°(380°/s) 4.28 rad (6.63 rad/s)	245°(310°/s) 4.28 rad (5.41 rad/s)	230°(460°/s) 4.01 rad (8.03 rad/s)		
	J3 axis	420°(520°/s) 7.33 rad (9.08 rad/s)	430°(410°/s) 7.50 rad (7.16 rad/s)	402°(520°/s) 7.02 rad (9.08 rad/s)		
	J4 axis	380°(550°/s) 6.63 rad (9.60 rad/s)	250°(545°/s) 4.36 rad (9.51 rad/s)	380°(550°/s) 6.63 rad (9.60 rad/s)	380°(560°/s) 6.63 rad (9.77 rad/s)	240°(560°/s) 4.19 rad (9.77 rad/s)
	J5 axis	250°(545°/s) 4.36 rad (9.51 rad/s)	720°(1500°/s) 12.57 rad (26.18 rad/s)	250°(545°/s) 4.36 rad (9.51 rad/s)	(Note 6) 240°(560°/s) 4.19 rad (9.77 rad/s)	720°(1500°/s) 12.57 rad (26.18 rad/s)
	J6 axis	720°(1000°/s) 12.57 rad (17.45 rad/s)		720°(1000°/s) 12.57 rad (17.45 rad/s)	720°(900°/s) 12.57 rad (15.71 rad/s)	
Max. load capacity at wrist	7 kg			4 kg		
Allowable load moment at wrist	J4 axis	16.6 N·m		8.86 N·m		
	J5 axis	16.6 N·m	4.0 N·m 5.5 N·m (option)	16.6 N·m	4.0 N·m 5.5 N·m (option)	
	J6 axis	9.4 N·m		9.4 N·m		
Allowable load inertia at wrist	J4 axis	0.47 kg·m ²		0.20 kg·m ²		
	J5 axis	0.47 kg·m ²	0.046 kg·m ² 0.15 kg·m ² (option)	0.47 kg·m ²	0.046 kg·m ² 0.083 kg·m ² (option)	
	J6 axis	0.15 kg·m ²		0.15 kg·m ²	0.067 kg·m ²	
Repeatability	± 0.02 mm		± 0.03 mm	± 0.02 mm		
Mass (Note 3)	25 kg	24 kg	27 kg	20 kg	19 kg	
Installation environment	Ambient temperature : 0~45°C Ambient humidity : Normally 75%RH or less (No dew nor frost allowed) Short term 95%RH or less (within one month) Vibration acceleration : 4.9m/s ² (0.5G) or less					

Note 1) In case of short distance motion, the axis speed may not reach the maximum value stated.

Note 2) Angle mounting needs J1 and J2 axis motion range restriction according with the payload, except for LR Mate 200iD/4S, /4SC and /4SH.

Note 3) Without controller.

Note 4) The liquids that deteriorate the sealing members, such as organic solvents, acids, alkalis, and chloric coolants, must not be used.

Note 5) Cleanliness of the clean type (/7C, /7LC, /4SC) is class 10 (ISO class 4) with white paint, antirust surface and food grade grease.

Note 6) In case of /4SC, J5 motion range is restricted to 236° (4.11rad).

FANUC

FANUC AMERICA CORPORATION
 3900 WEST HAMLIN ROAD
 ROCHESTER HILLS MI 48309-3253

