

FANUC Robot CR-35iA



Features

The FANUC CR-35iA Robot is a 35kg payload collaborative robot that can work without safety fences.

Collaborative Operation

- Operates in close proximity to humans in a shared workspace without safety fences.
- Works in cooperation with a human operator. (example: heavy workpiece transfer, parts assembly)

Safety Function

- Stops safely when it comes in contact with a human operator.
- Safe and gentle green cover reduces impact forces and pinch points by providing a soft barrier between a human operator and the robot arm.
- Certified to meet the requirements of international standard ISO 10218-1.

Intelligence and High Reliability

- Latest intelligent functions such as *iR*Vision (Integrated vision) are available.
- The CR-35iA is designed and built with the precision and reliability of all FANUC robots.

Application Examples



Loading spare tires into automobiles

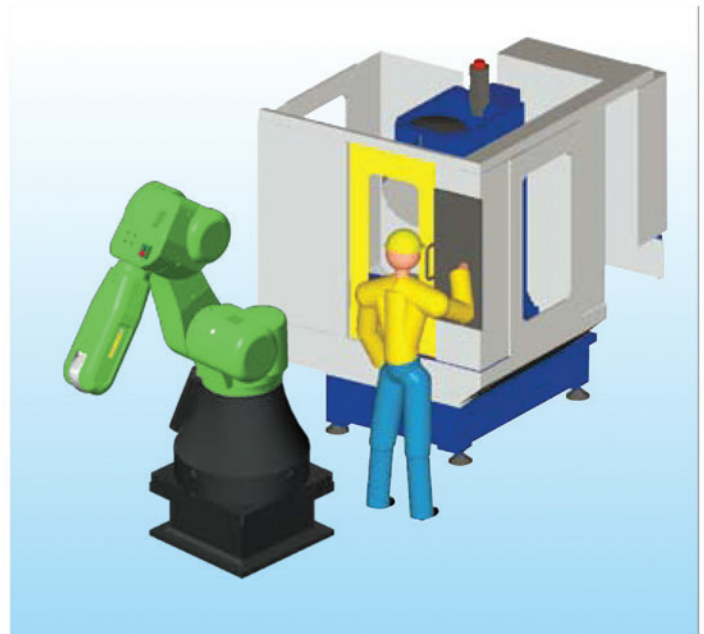

Loading/unloading machine tools

Operating space

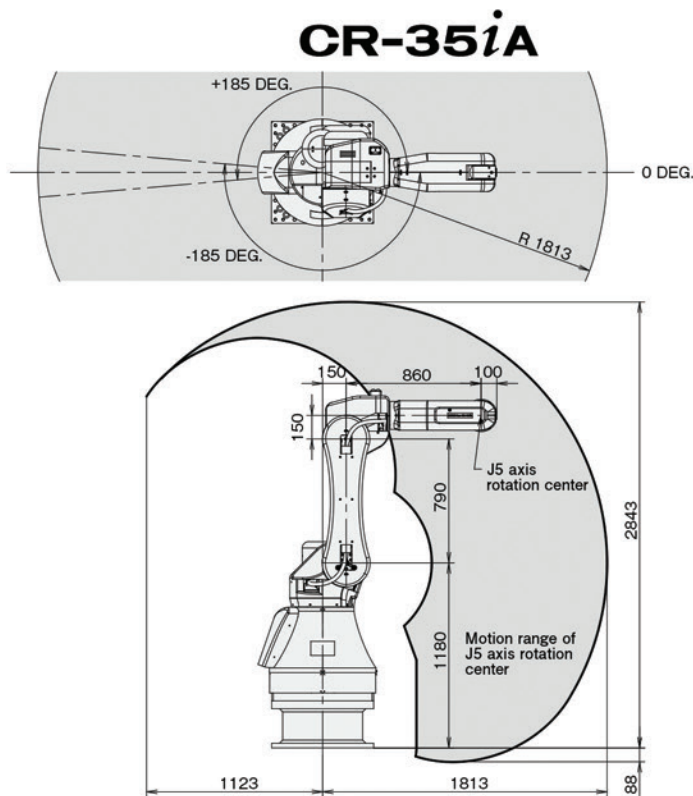

Specifications

Model		CR-35iA	
Type		Articulated Type	
Controlled axes		6 axes (J1, J2, J3, J4, J5, J6)	
Reach		1813 mm	
Installation		Floor	
Motion range	J1 axis rotation	340° / 370°(Option) 5.93 rad / 6.46 rad(Option)	
	J2 axis rotation	165° 2.88 rad	
	J3 axis rotation	312° 5.45 rad	
	J4 axis wrist rotation	400° 6.98 rad	
	J5 axis wrist swing	220° 3.84 rad	
	J6 axis wrist rotation	900° 15.71 rad	
Max. load capacity at wrist		35 kg	
Max. load capacity on J3 casing		2 kg	
Maximum speed (Note 1)		250 mm/s(Max. 750 mm/s) (Note 2)	
Allowable load moment at wrist	J4 axis	110 N·m	
	J5 axis	110 N·m	
	J6 axis	60 N·m	
Allowable load inertia at wrist	J4 axis	4.00 kg·m ²	
	J5 axis	4.00 kg·m ²	
	J6 axis	1.50 kg·m ²	
Drive method		Electric servo drive by AC servo motor	
Repeatability		±0.08 mm	
Mass (Note 3)		990 kg	
Installation environment		Ambient temperature	: 0 to 45°C
		Ambient humidity	: Normally 75 %RH or less (No dew nor frost allowed) Short term Max.95 %RH or less (within one month)
		Vibration acceleration	: 4.9 m/s ² (0.5G) or less

Note 1) In case of short distance motion, the speed may not reach the maximum value stated.

Note 2) If the area is monitored by a safety sensor (located separately).

Note 3) Without controller.

FANUC

FANUC AMERICA CORPORATION
3900 WEST HAMLIN ROAD
ROCHESTER HILLS MI 48309-3253



MARKETING@FANUCAMERICA.COM

FANUCAMERICA.COM 888-FANUC-US